

TUFFALOY OFFSET HOLDERS

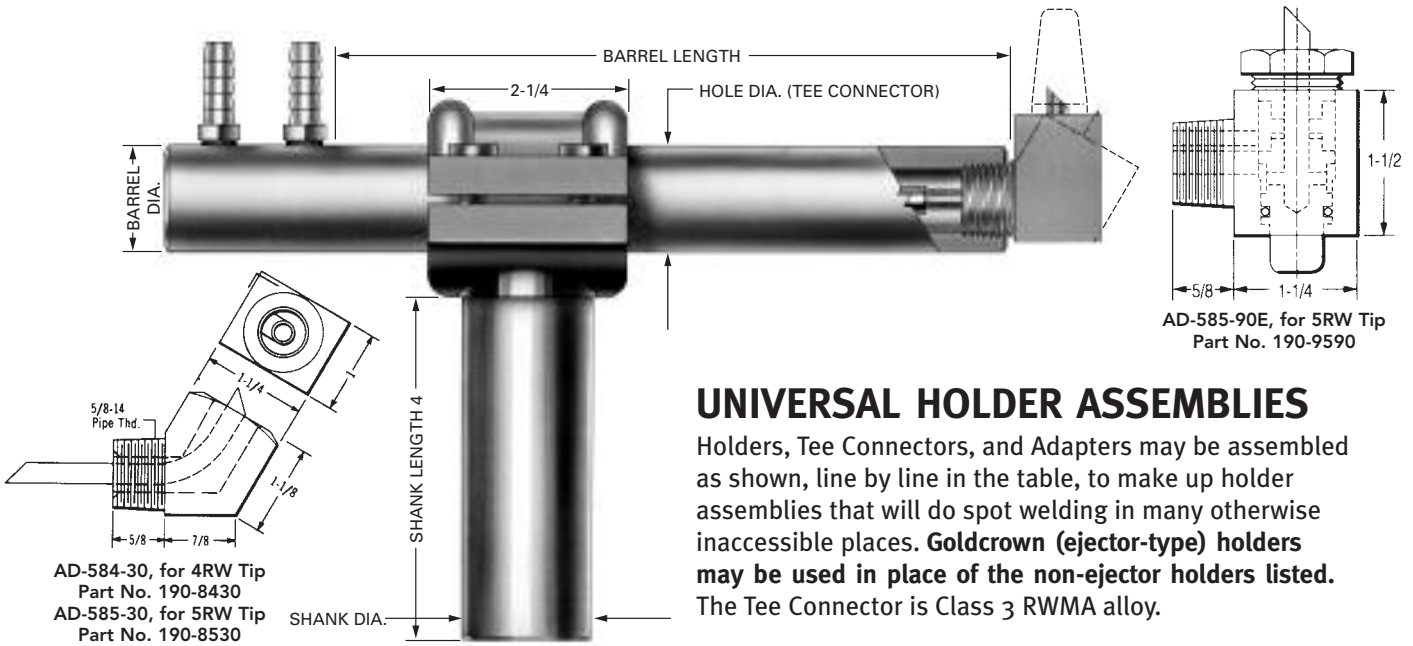

UNIVERSAL HOLDER ASSEMBLIES

Holders, Tee Connectors, and Adapters may be assembled as shown, line by line in the table, to make up holder assemblies that will do spot welding in many otherwise inaccessible places. **Goldcrown (ejector-type) holders may be used in place of the non-ejector holders listed.** The Tee Connector is Class 3 RWMA alloy.

HOLDERS				TEE CONNECTORS			
Barrel Dia.	Barrel Length	Description.	Part No.	Hole Dia.	Shank Dia.	Description	Part No.
1	8	N-08085-A	325-0235	1	1	T-1-1	192-1100
1-1/4	8	N-10085-A	325-0295	1-1/4	1	T-1	192-1000
1-1/4	8	N-10085-A	325-0295	1-1/4	1	T-1	192-1000
1-1/4	8	N-10085-A	325-0295	1-1/4	1-1/4	T-125	192-1250
1-1/4	8	N-10085-A	325-0295	1-1/4	1-1/4	T-125	192-1250
1-1/4	8	N-10085-A	325-0295	1-1/4	1-1/4	T-125	192-1250
1-1/2	8	N-12085-A	325-0375	1-1/2	1-1/2	T-15	192-1500
1-1/2	8	N-12085-A	325-0375	1-1/2	1-1/2	T-15	192-1500
1-1/2	8	N-12085-A	325-0375	1-1/2	1-1/2	T-15	192-1500

ADAPTERS TO CHOOSE FROM			
Tip Socket	Angle Degrees	Description	Part No.
4RW	90	AD-584-90	190-8490
4RW	30	AD-584-30	190-8430
5RW	90	AD-585-90	190-8590
5RW	30	AD-585-30	190-8530
6RW	90	AD-586-90	190-8690

WELDER ARMS TUFFALOY

Class 2 spot welding machine arms made by Tuffaloy reduce set up time and give longer life.

Electrode holder shanks can be attached to these arms from the front, by bolting the cap over them. This means no extra clearance is required between the arms to allow running a shank up (or down) into a hole in the arm. It makes the insertion of Tuffaloy multiple-welding holders much easier.

One of the most common failures of welder arms is the destruction of the bolt hole threads, due to the relatively soft copper involved. Tuffaloy arms have a transverse steel bar insert in which the bolt hole threads are cut. This provides greatly increased thread life.

Standard arm configurations are shown in the table. Special arms are also available.

A Arm Diameter	B Hole Diameter*	C Arm Length	Description	Part No.
2	1	12	SH-7320-1	630-7321
		16	SH-7320-2	630-7322
		20	SH-7320-3	630-7323
2-1/2	1-1/4	12	SH-7320-4	630-7324
		16	SH-7320-5	630-7325
		20	SH-7320-6	630-7326
3	1-1/2	12	SH-7320-7	630-7327
		16	SH-7320-8	630-7328
		20	SH-7320-9	630-7329

*These diameters will be supplied unless otherwise specified.

